



melogranoblu

LEGEND



CLEAR GLASS



FROSTED GLASS



RULED CLEAR GLASS



RULED FROSTED GLASS



METALLIZED



INNER LIGHT



REFLECTED LIGHT



SUSPENSION LAMP



WALL LAMP



TABLE LAMP

INDEX

SOAP	9	DIESIS	104
SOAP SPHERE	10	GAMMA	106
SOAP DOME SUSPENSION	14	JANUS	108
SOAP DOME TABLE	16	LAMBDA	112
		LHASA	114
BULLET	19	OMEGA	116
		ONION	120
SERENDIPITY	23	ORGANIC	122
SERENDIPITY SUSPENSION	24	SIGMA	124
SERENDIPITY TABLE	26	STIGMA	128
		THETA	130
RAPA NUI	31	VITAMINE	132
		VITAMINE METAL	134
OPIUM	37	LED CEILING LIGHTS	136
		INNER LIGHTS	139
PERFUME	43	TUBE	140
PERFUME EGG	44		
PERFUME PINECONE	48	OPERA	143
PERFUME SPHERE	50	TURANDOT	144
PERFUME SPEAR	54	CARMEN	145
PERFUME DJED	57	DROP	146
		POSEIDON EGG	147
MOONSHADOW	59	POSEIDON GLOBE	148
		ZUCCA	149
GOTHAM	63	BAJADERE	150
		CALAF	151
HYDRA SYSTEM	69	NINIVE	152
COMPONENTS	83	TIMUR	153
GLASSES	84	LIU "A"	154
ACORN	86	LIU "B"	155
ALPHA	88	LIU "C"	156
BERRY	90	MOON	157
BERRY METAL	92	TOP CHANDELIER	158
BETA	96	ACCESSORIES	159
DATURA	98	TASSELS AND CABLES	160
DELTA	100		

THE FACTORY OF EMOTIONS

CONCEIVED AND FOUNDED IN 1997 BY ERMANNO ROCCHI AND MASSIMO CREMA, MELOGRANOBLU IS AN ITALIAN INTERIOR LIGHTING COMPANY. OVER THE YEARS, THE COMPANY HAS DEVELOPED A WIDE RANGE OF SOLUTIONS FOR INTERIOR LIGHTING DESIGN, SUITABLE FOR HOMES OR OFFERING MORE IMPRESSIVE INSTALLATIONS FOR LARGE ARCHITECTURAL SETTINGS.

MELOGRANOBLU CREATIONS ARE VERITABLE SPECTACLES OF LIGHT, FOCUSING ON THE SENSORY AND EMOTIONAL EFFECT OF LIGHT THROUGH GLASS.

DESIGN PROJECTS IN WHICH ALL FORMS OF GLASS ARE CONCEIVED AND DESIGNED ACCORDING TO THE EFFECTS THEY CAN GENERATE THROUGH LIGHT.

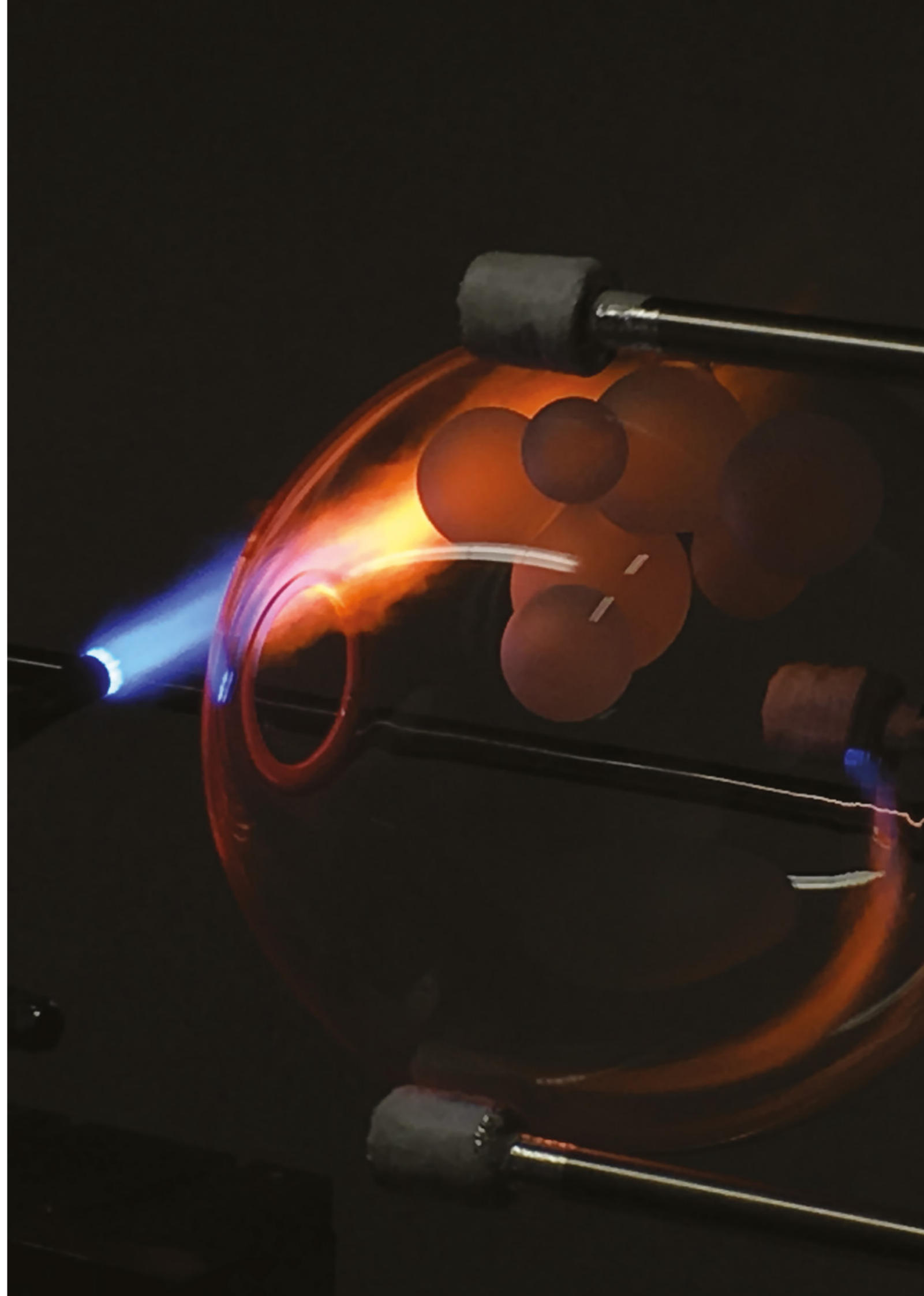

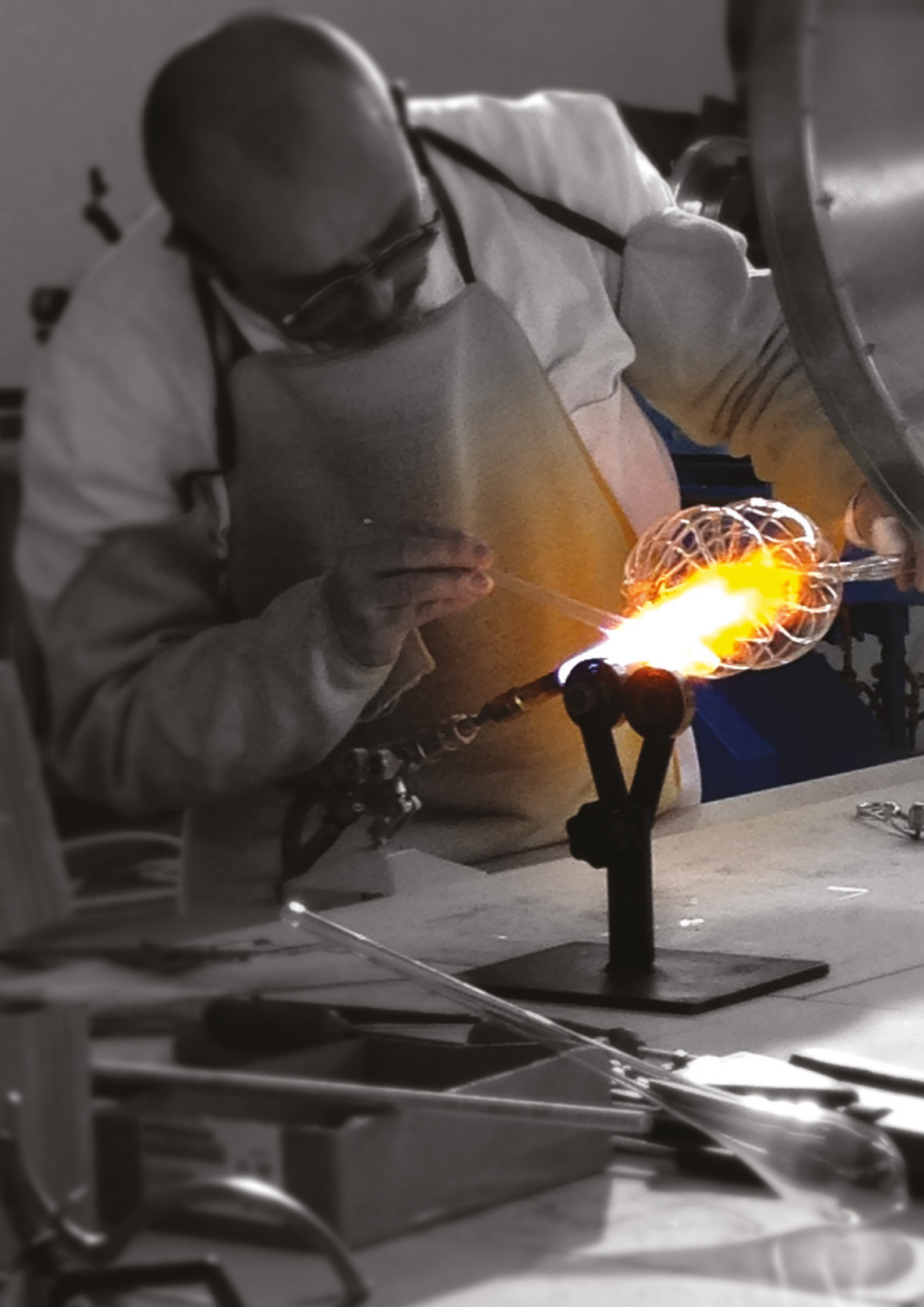

CRAFTED PRODUCTION AND INDUSTRIAL ORGANISATION

ALL MELOGRANOBLU DESIGNS ARE CONCEIVED, DEVELOPED, ENGINEERED AND PRODUCED IN THE COMPANY. A STRUCTURE ORGANISED TO MANAGE AND GUARANTEE "MADE IN ITALY" QUALITY THROUGHOUT THE ENTIRE PRODUCTION PROCESS.

UNIQUE PIECES, THE SAME YET DIFFERENT SINCE THEY ARE MADE WITH PASSION BY SKILLED HANDS THAT CREATE ARTWORKS FROM GLASS.

MADE-TO-ORDER

MELOGRANOBLU'S IN-HOUSE GROUP OF DESIGNERS WORKS IN COLLABORATION WITH THE CLIENT, DEVELOPING EACH SPECIFIC DESIGN IDEA TO ACHIEVE A MADE-TO-MEASURE LIGHT INSTALLATION.

MELOGRANOBLU MADE-TO-ORDER DESIGNS, ALL DEVELOPED AND ENGINEERED WITHIN THE COMPANY, ARE DELIVERED TO THE CLIENT COMPLETE WITH DETAILED INSTRUCTIONS TO GUIDE EASY INSTALLATION IN TOTAL SAFETY.





SOAP

TRANSPARENCY IN TRANSPARENCY. SOAP COLLECTION PLAYS WITH THE REVELATORY POWER OF LIGHT. THE GLASS SCULPTURE INSIDE IS REVEALED ONLY WHEN THE LIGHT SOURCE, AS IF BY MAGIC, MAKES THE EXTERNAL MİRRORED ELEMENT TRANSPARENT, CREATING A SUBLIME AND FASCINATING GAME OF APPEARANCES. THE ENERGY RELEASED FROM THE INSIDE IS A MARRIAGE OF TECHNIQUE AND GENIUS.

SOAP SPHERE



SUSPENSION LAMP

METALLIZED HAND-BLOWN GLASS SPHERE
INNER FROSTED BUBBLE SCULPTURE.

Glass dimension \varnothing 30 cm, light source 8W LED 2800k. Metal parts in brushed brass.
Electric cable 2,00 mt lenght coated metallic mesh Titanium T08.

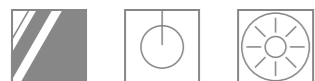



SOAP DOME

SUSPENSION LAMP

METALLIZED HAND-BLOWN GLASS DOME,
INNER FROSTED BUBBLE SCULPTURE.

Glass dimension h. 30 - ø 30 cm, light source 8W LED 2800k. Metal parts in brushed brass.
Electric cable 2,00 mt lenght coated metallic mesh Titanium T08.

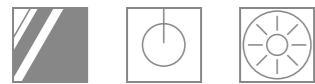

SOAP DOME

TABLE LAMP

TRANSPARENT HAND-BLOWN GLASS DOME,
INNER TRANSPARENT BUBBLE SCULPTURE.

Glass dimension h. 30 - ø 30 cm, light source 8W LED 2800k. Metal parts in brushed brass.
Electric cable 2,50 mt lenght coated metallic mesh Titanium T08.





BULLET

THE TRANSPARENT EFFECT OF HAND-BLOWN GLASS
MAKES BULLET SUSPENDED LAMP A FUNCTIONAL
AND DESIGN DECOR ELEMENT.

BULLET

SUSPENSION LAMP

CLEAR HAND-BLOWN RULED GLASS.

Glass dimension h. 30 - ø 15 cm, light source 4W LED 2800k. Black varnished metal parts.
Electric cable 2,00 mt. lenght coated metallic mesh Black T21.

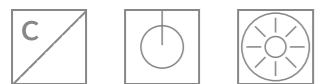



SERENDIPITY

ORGANIC, NATURAL AND PRIMORDIAL SHAPES CHARACTERIZE SERENDIPITY. FROSTED GLASS SINGLE UNIT, WHOSE SOFT SHAPE REFLECT THE BEAUTIFUL IMPERFECTION OF NATURE.

SERENDIPITY

SUSPENSION LAMP

FROSTED HAND-BLOWN GLASS.

Glass dimension h. 55 - ø 18 cm, light source 4 x 2,5W LED 2800k.
Electric cable 2,00 mt. lenght coated metallic mesh Copper T00.

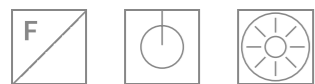

SERENDIPITY

TABLE LAMP

FROSTED HAND-BLOWN GLASS.

Glass dimension h. 55 - ø 18 cm, light source 4 x 2,5W LED 2800k dimmer control.
Electric cable 2,00 mt. length coated metallic mesh Copper T00.







RAPA NUI

THINK ABOUT PRIMORDIAL STATUES, BUT IT IS LIGHT GLASS INDEED. A TABLE LAMP WITH GOLD AND STEEL FINISHES AND MIRRORED EFFECTS MIXED WITH A STRONG DESIGN. A TRIUMPH OF SOLIDITY WITH THE TOUCH OF LIGHTNESS OF HAND-BLOWN GLASS.

RAPA NUI

TABLE LAMP

METALLIZED SILVER OR GOLD HAND-BLOWN GLASS.

SMALL_Metallized gold hand-blown glass.

Dimension h. 15 - ø 18 cm. Light source 1 x 2,5W LED 2800k dimmer control.
Metallic varnished base. Electric cable 2,00 mt. lenght coated metallic mesh Black T21.

LARGE_Metallized silver hand-blown glass.

Dimension h. 24 - ø 18 cm. Light source 3 x 2,5W LED 2800k dimmer control.
Metallic varnished base. Electric cable 2,00 mt. lenght coated metallic mesh Black T21.







OPIUM

FROM NATURE, THIS IS A PORTRAIT OF REALITY. THIS SUSPENDED LAMP MADE WITH GOLD METALLIZED HAND-BLOWN GLASS, WHOSE SHAPE LOOKS LIKE A POPPY CAPSULE, IS THE PICTURE OF NATURAL BEAUTY.

OPIUM



SUSPENSION LAMP

GOLD METALLIZED HAND-BLOWN GLASS.

Glass dimension h. 19 - ø 20 cm, light source G9 halo 35W or LED 3W.

Electric cable 2,00 mt. lenght coated metallic mesh Brown T20.

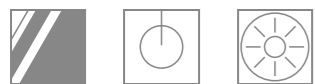





PERFUME

PENDANT LAMPS THAT TRANSCEND THEIR LIGHTING FUNCTION TO AROUSE EMOTION, GENERATED BY A SPECTACLE OF LIGHTS AND REFLECTIONS. PURE GLASS SHAPES, ESSENTIAL STYLE. POETRY OF LIGHT THAT GAINS EXPRESSION IN A SIMPLE, LINEAR DESIGN. CRAFTED PRODUCTION WHOSE IDENTITY LIES ON THE BORDER BETWEEN DESIGN AND APPLIED ART.

PERFUME EGG

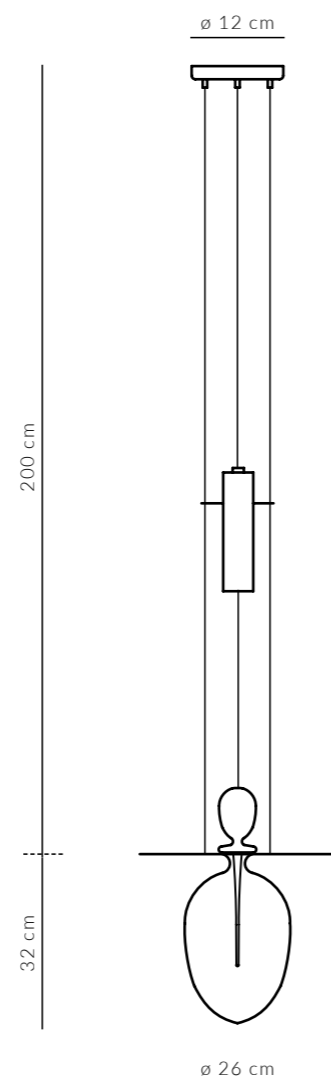

SUSPENSION LAMP

TRANSPARENT HAND-BLOWN GLASS EGG SHAPE.

Glass dimension h. 32 - \varnothing 26 cm, light source 3W LED 2800k. Metal parts in anodised aluminium.
Complete with decorative glass cap available in transparent, frosted, platinum and gold finishing.

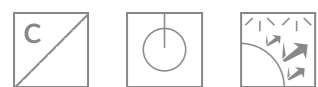



PERFUME PINECONE

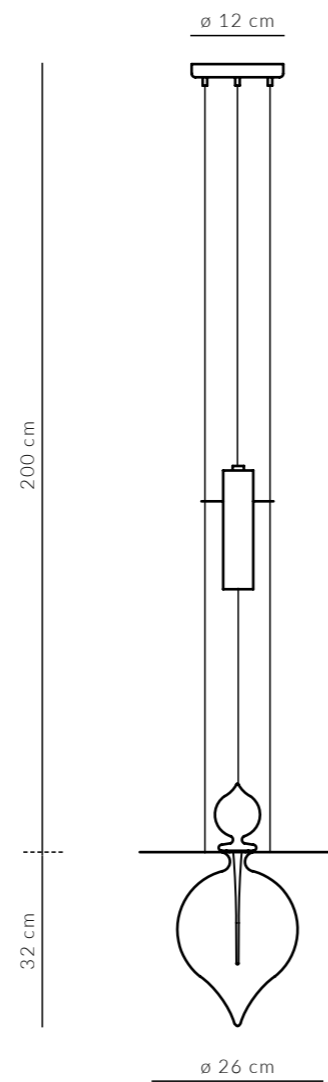

SUSPENSION LAMP

TRANSPARENT HAND-BLOWN GLASS PINECONE SHAPE.

Glass dimension h. 32 - \varnothing 26 cm, light source 3W LED 2800k. Metal parts in anodised aluminium.
Complete with decorative glass cap available in transparent, frosted, platinum and gold finishing.

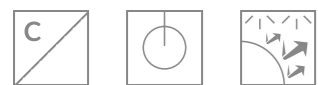

PERFUME SPHERE

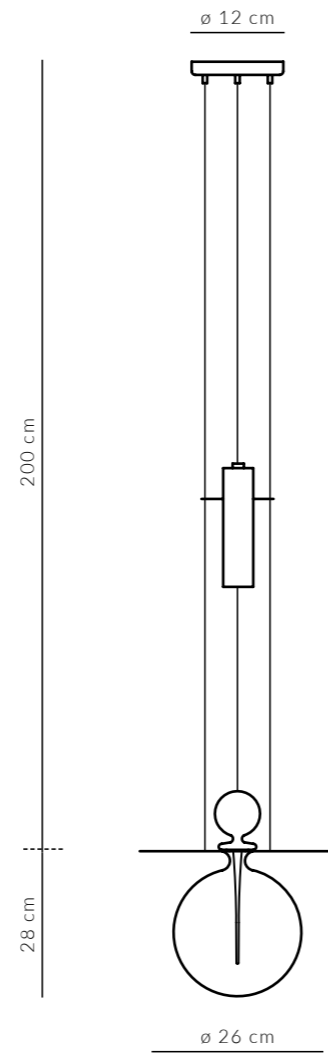

SUSPENSION LAMP

TRANSPARENT HAND-BLOWN GLASS SPHERE SHAPE.

Glass dimension h. 28 - \varnothing 26 cm, light source 3W LED 2800k. Metal parts in anodised aluminium.
Complete with decorative glass cap available in transparent, frosted, platinum and gold finishing.

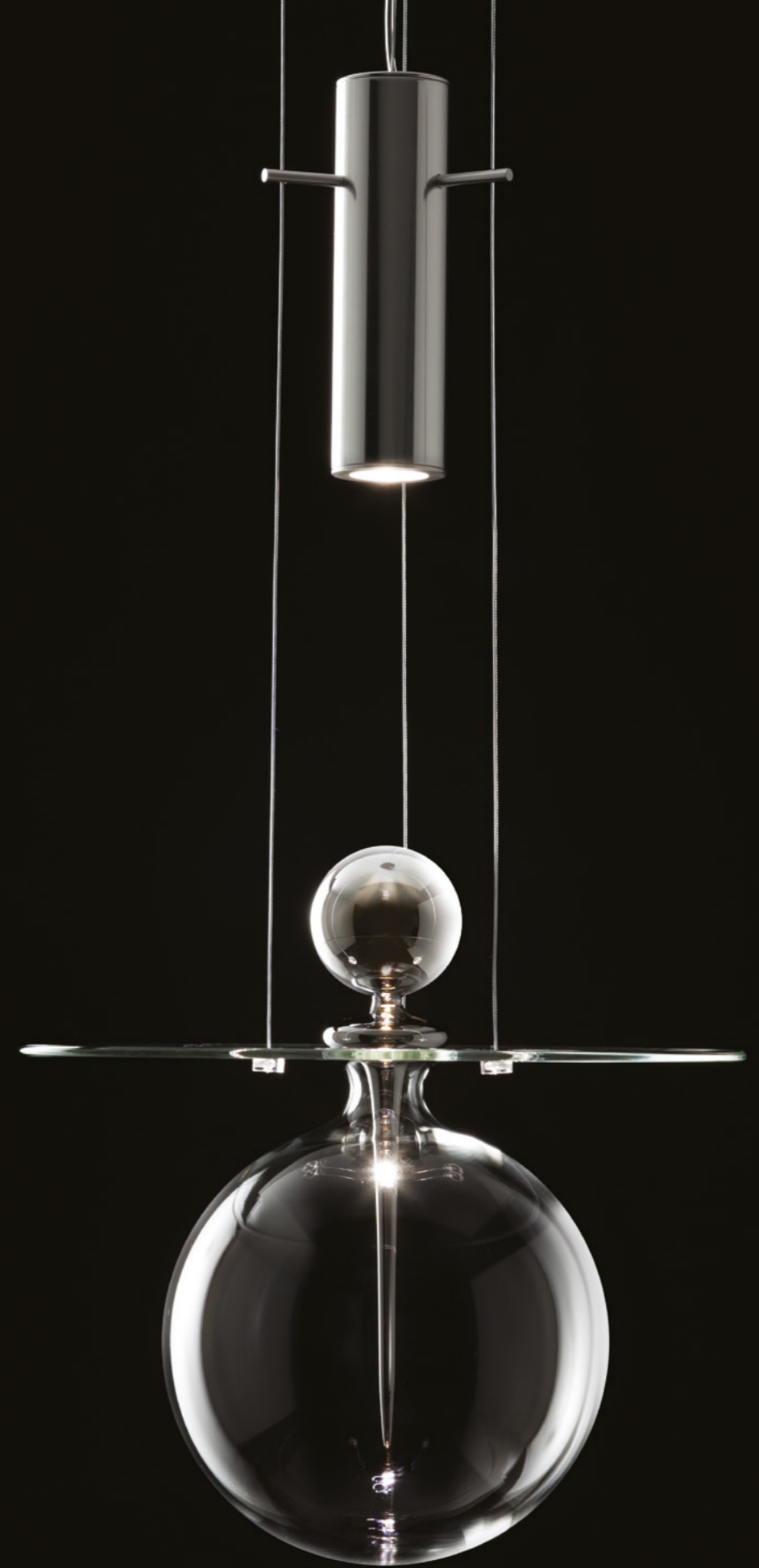
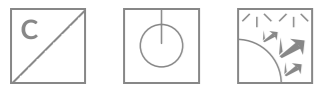



PERFUME SPEAR

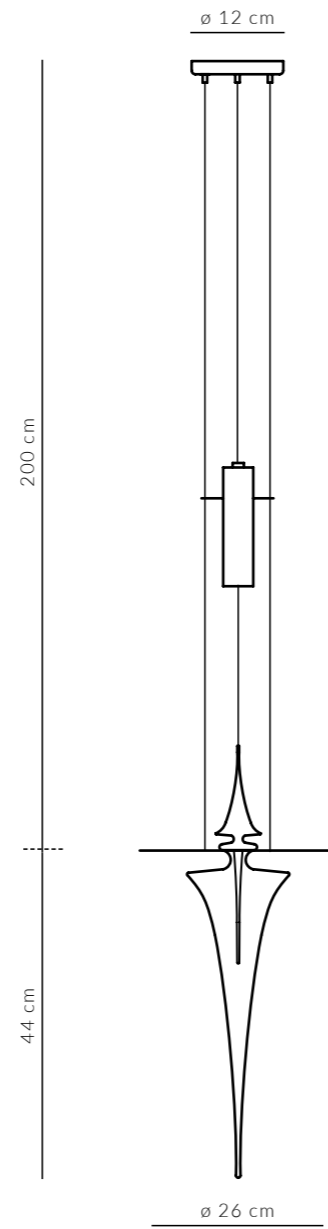

SUSPENSION LAMP

TRANSPARENT HAND-BLOWN GLASS SPEAR SHAPE.

Glass dimension h. 44 - \varnothing 26 cm, light source 3W LED 2800k. Metal parts in anodised aluminium.
Complete with decorative glass cap available in transparent, frosted, platinum and gold finishing.

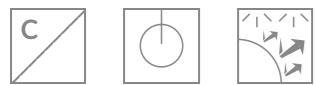



PERFUME DJED

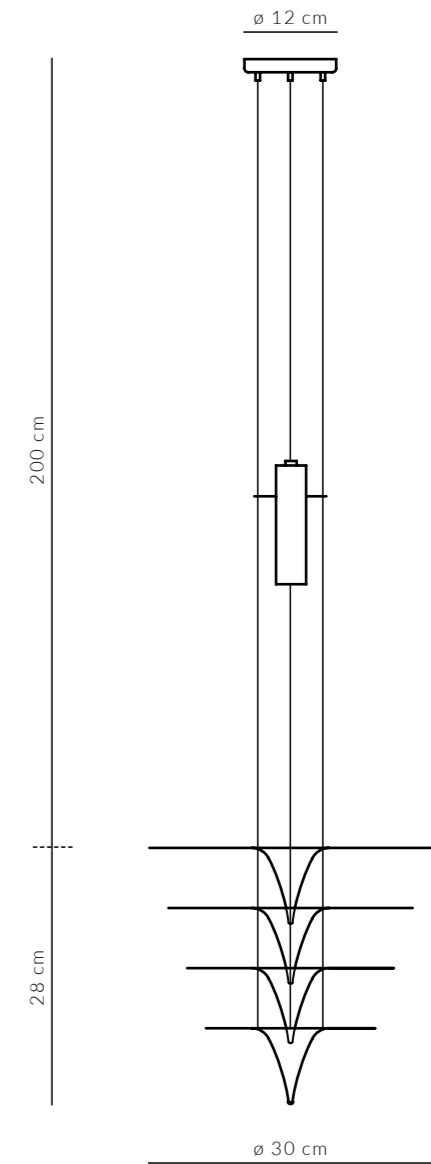

SUSPENSION LAMP

FROSTED HAND-BLOWN GLASS DJED SHAPE.

Glass dimension h. 28 - \varnothing 30 cm, light source 3W LED 2800k. Metal parts in anodised aluminium.

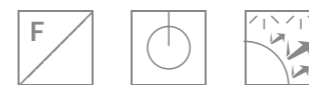



MOONSHADOW

LAMP WITH INDIRECT LIGHT AND ORGANIC, ESSENTIAL DESIGN; THE SIMPLEST SHAPE BECOMES LIGHT. WHITE GLASS COMES TO LIFE THROUGH LIGHT THAT ENHANCES ITS VOLUME AND DESIGN. BEADS OF LUMINOUS, OPALESCENT GLASS. REFLECTIONS AND SHADOWS MEET ON THE TRANSLUCENT SURFACE, GIVING THE SETTING A LUNAR GLOW WITH SOFTNESS, GRACE AND LIGHTNESS.

MOONSHADOW

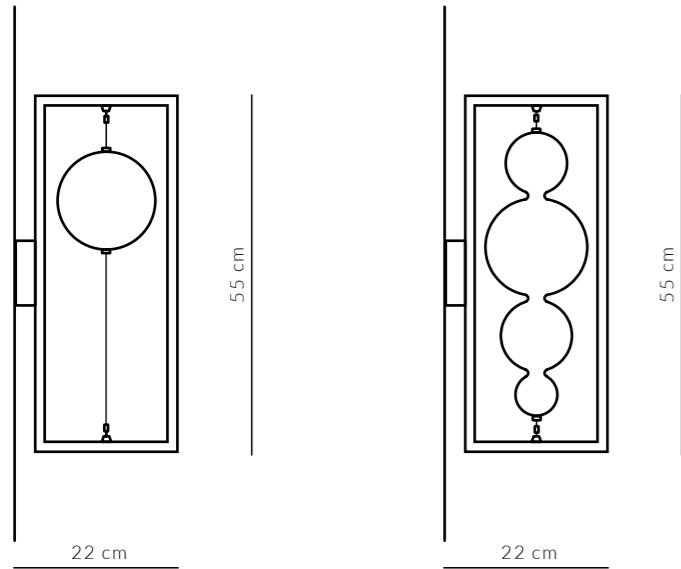

MODEL "A"

MODEL "B"

WALL LAMP WITH REFLECTED LIGHT.

MODEL "A" _Hand-blown frosted glass sphere \varnothing 15 cm. Body glossy white dimension h. 55 x 22 cm. Light source strip LED 150 LED/meter x 10W 3000k. Frame colour available in white, red or black.

MODEL "B" _Hand-blown frosted glass shape h. 43 - \varnothing 15 cm. Body glossy white dimension h. 55 x 22 cm. Light source strip LED 150 LED/meter x 10W 3000k. Frame colour available in white, red or black.





GOTHAM

LIGHTING STRUCTURES, HIGH IMPACT GLASS PENDANT LAMPS, WHOSE DISTINCTIVE CHARACTER PUTS THEM BEYOND ALL DEFINITIONS. METROPOLITAN STYLE, THE DREAM OF A NOCTURNAL MEGALOPOLIS, WHICH ONLY THE MOST VISIONARY IMAGINATION CAN ENVISAGE. AN IMPRESSIVE DESIGN, SOLID AND REASSURING, ENCHANTS THE GAZE AND THE SENSES.

GOTHAM

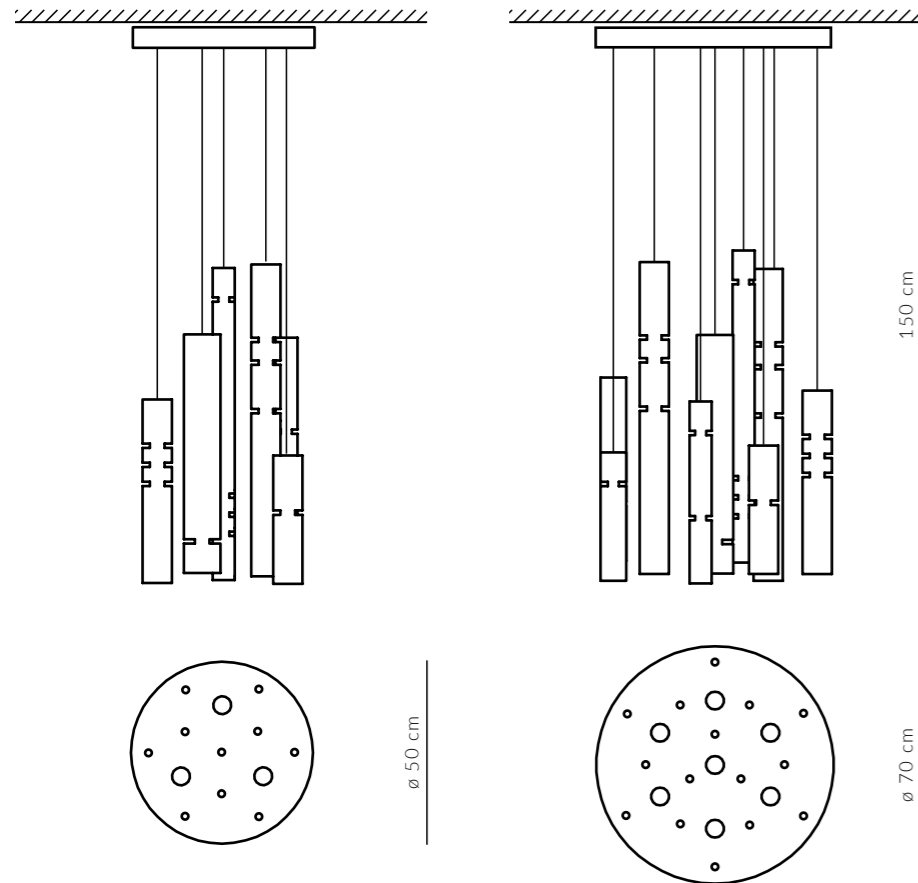

CHANDELIER

SMALL_Round metal ceiling \varnothing 50 cm mirror finishing.
 3 x 10W power LED dimmable, 2700k optic 10°
 10 clear and frosted mixed glass shapes.

LARGE_Round metal ceiling \varnothing 70 cm mirror finishing.
 7 x 10W power LED dimmable, 2700k optic 10°
 15 clear and frosted mixed glass shapes.



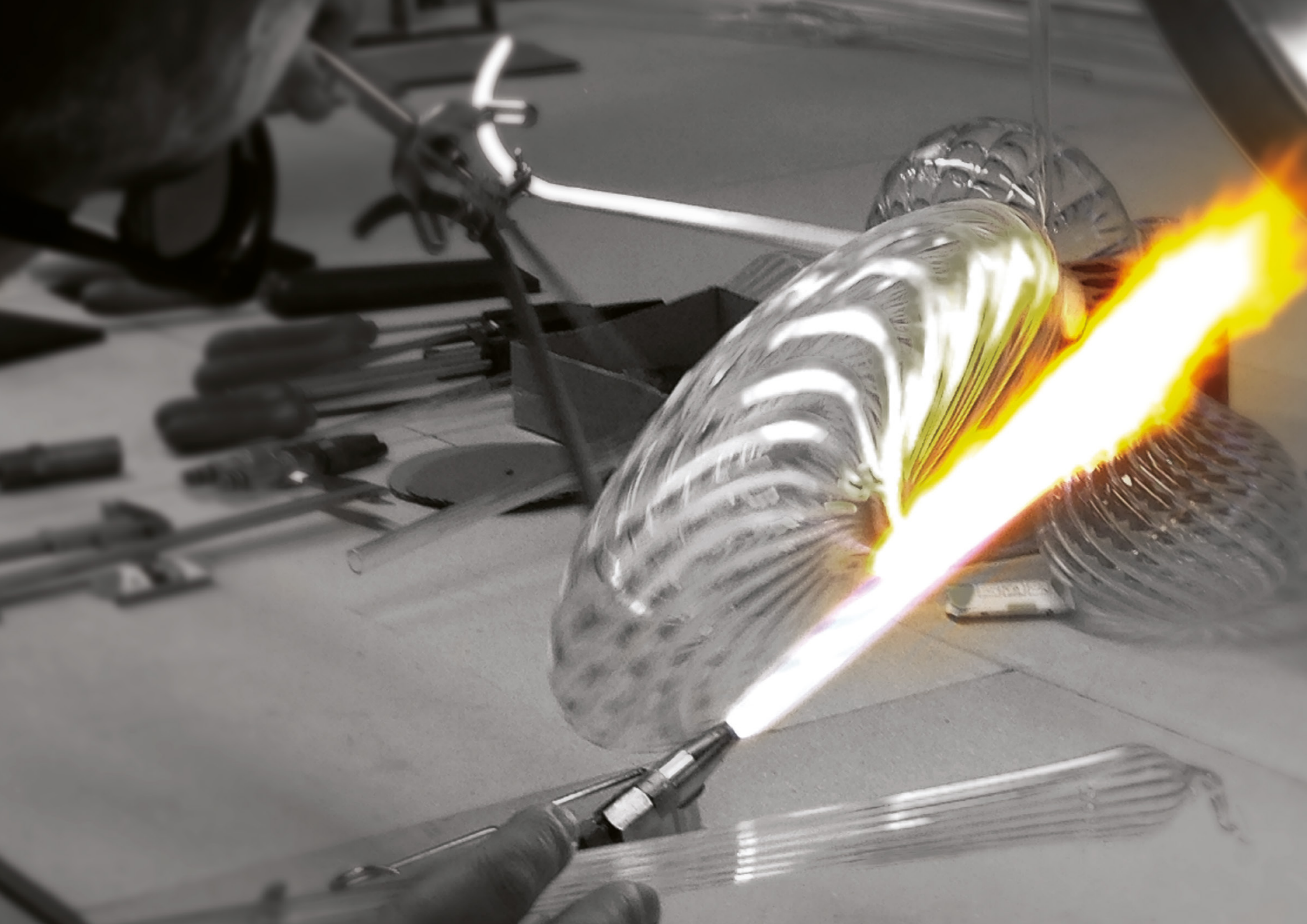



HYDRA SYSTEM

HYDRA IS A MODULAR LIGHTING SYSTEM FOR INTERIORS CREATED BY MELOGRANOBLU FOR DESIGNING AND CREATING ALLURING AND SOPHISTICATED LIGHTING COMPOSITIONS WITH GREAT EASE.

SHAPES IN BLOWN GLASS, CLEAR OR FROSTED, SUSPENDED USING COLOURED TUBULAR METAL LINKS, REFLECT THE LIGHT IN THE ROOM TO CREATE EVOCATIVE ATMOSPHERES.

VERSATILITY, LIGHTNESS, EASY INSTALLATION AND FREEDOM OF DESIGN ARE ITS DISTINCTIVE FEATURES.

WITH HYDRA YOU CAN CREATE COUNTLESS LIGHT CONFIGURATIONS SUITED TO ALL ARCHITECTURAL INTERIORS, BE THEY RESIDENTIAL OR CONTRACT.

THE IN-HOUSE GROUP OF DESIGNERS WORKS IN CLOSE SYNERGY WITH THE CLIENT IN CREATING SPECTACULAR COMPOSITIONS STUDIED FOR THE SPECIFIC INTERIOR DESIGN PROJECT. STARTING OUT WITH A CONCEPT, IT DEVELOPS A DETAILED SHOP DRAWING COMPLETE WITH INSTALLATION INSTRUCTIONS.



LIGHT CREATES
EVOCATIVE
ATMOSPHERES







VERSATILITY
AND FREEDOM
OF DESIGN





HYDRA SYSTEM

COMPONENTS

A LIGHT SOURCE
See page 82

B FIXING ACCESSORIES
See page 82

C METALLIC MESH ROPES
See page 83

D GLASSES
See page 84

A LIGHT SOURCE



LED recessed projector 10W24Vdc 2700k cri93 optics 6° circular body ø 85 mm.

Hydra System is also customizable with:

- LED CEILING LIGHT_See page 136
- INNER LIGHT_See page 139

B FIXING ACCESSORIES



CEILING FIXING SUPPORT

FLOOR FIXING SUPPORT

GLASS FIXING METAL PIN

C METALLIC MESH ROPES

- #T11 Red
- #T34 Fuxia
- #T39 Orange
- #T26 Gold
- #T36 Purple
- #T35 Wistaria
- #T12 China Blue
- #T29 Turquoise
- #T08 Titanium
- #T00 Copper
- #T20 Brown
- #T07 Silver
- #T21 Black



COLOURED METALLIC MESH ROPE TO HANG GLASSES.

Colors in this catalogue may lightly vary because of printing. melgranoblu reserve the right to modify products and colors, without notice, in order to make technical improvements.

D GLASSES

- 1 ACORN page 86
- 2 ALPHA page 88
- 3 BERRY page 90 | BERRY METAL page 92
- 4 BETA page 96
- 5 DATURA page 98
- 6 DELTA page 100
- 7 DIESIS page 104
- 8 GAMMA page 106
- 9 JANUS page 108
- 10 LAMBDA page 112
- 11 LHASA page 114
- 12 OMEGA page 116
- 13 ONION page 120
- 14 ORGANIC page 122
- 15 SIGMA page 124
- 16 STIGMA page 128
- 17 THETA page 130
- 18 VITAMINE page 132 | VITAMINE METAL page 134

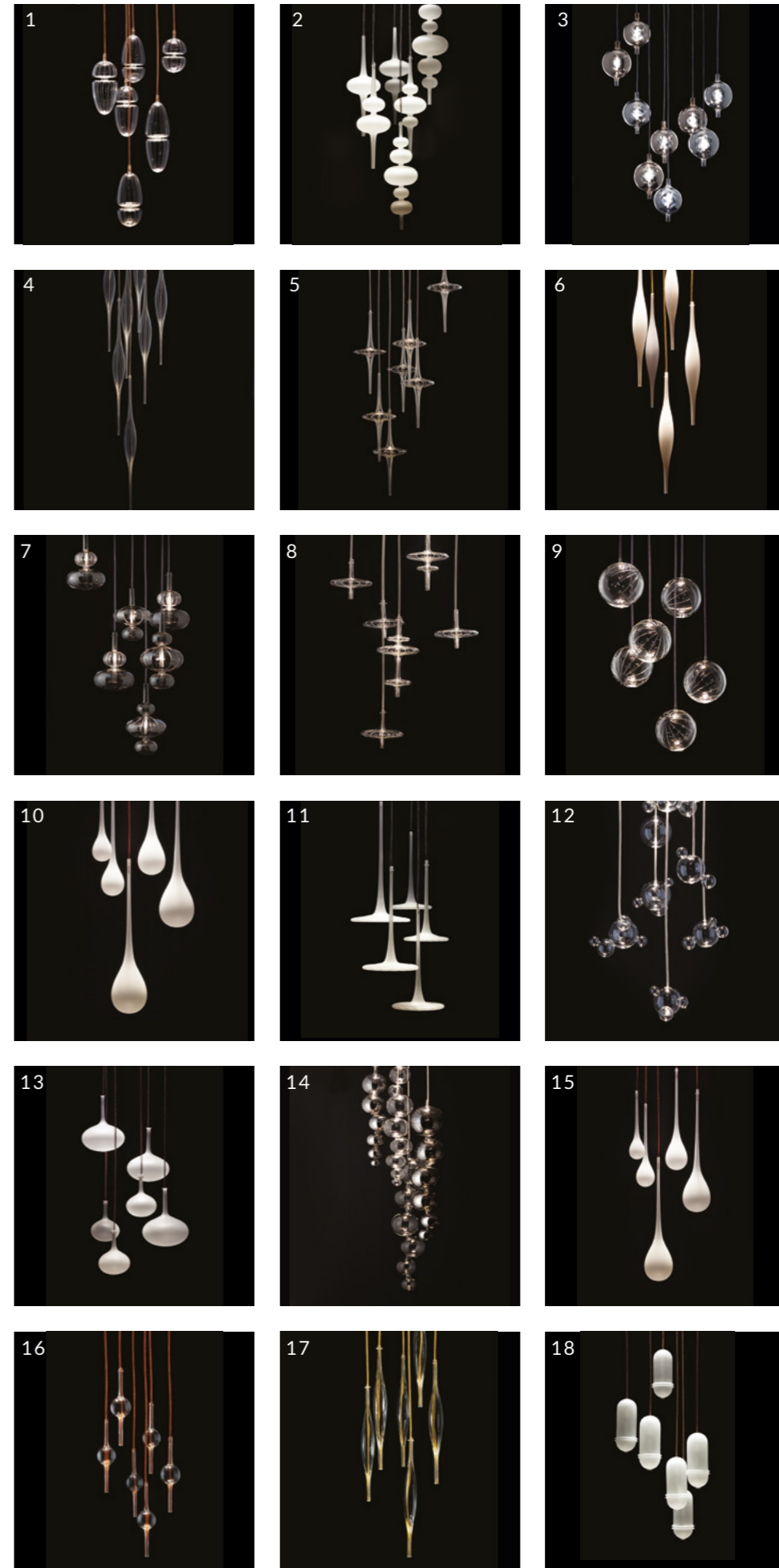

HYDRA

ACORN



CLEAR OR FROSTED HAND-BLOWN RULED GLASS PENDANT.

4 shapes available: ① h. 21,5 - ø 12,5 cm. ② h. 30 - ø 12,5 cm. ③ h. 30 - ø 12,5 cm. ④ h 38,5 - ø 12,5 cm.



HYDRA

ALPHA

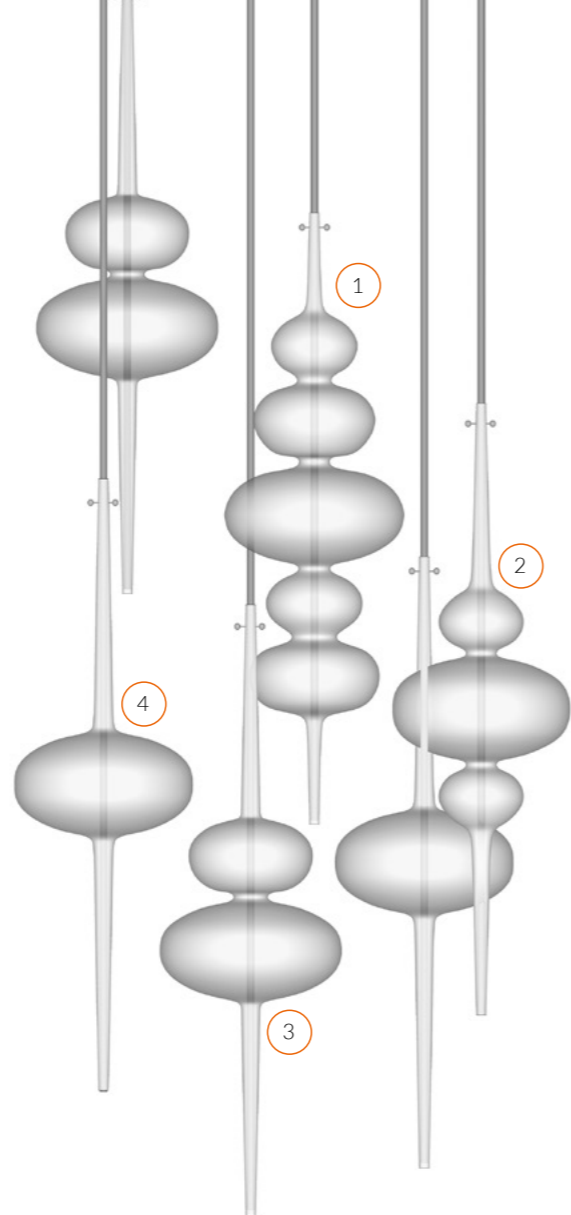

CLEAR OR FROSTED HAND-BLOWN GLASS PENDANT.

4 shapes available: ① h. 45 - ø 15,5 cm. ② h. 45 - ø 15,5 cm. ③ h. 45 - ø 15,5 cm. ④ h 45 - ø 15,5 cm.
Additional inner light can be used with this model (see page 139).



HYDRA

BERRY

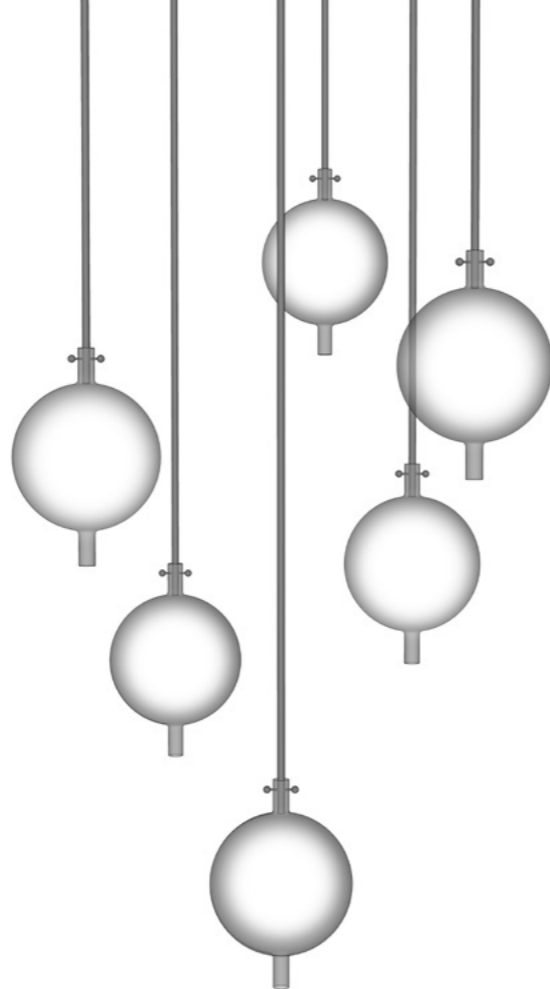

CLEAR HAND-BLOWN GLASS PENDANT.

One size only: h. 24 - ø 16 cm.



HYDRA

BERRY METAL



SILVER OR PINK GOLD METALLIZED HAND-BLOWN GLASS PENDANT.

One size only: h. 24 - ø 16 cm.

Additional inner light can be used with this model (see page 139).



Example of Berry Metal
with inner light.
See page 139.



HYDRA

BETA

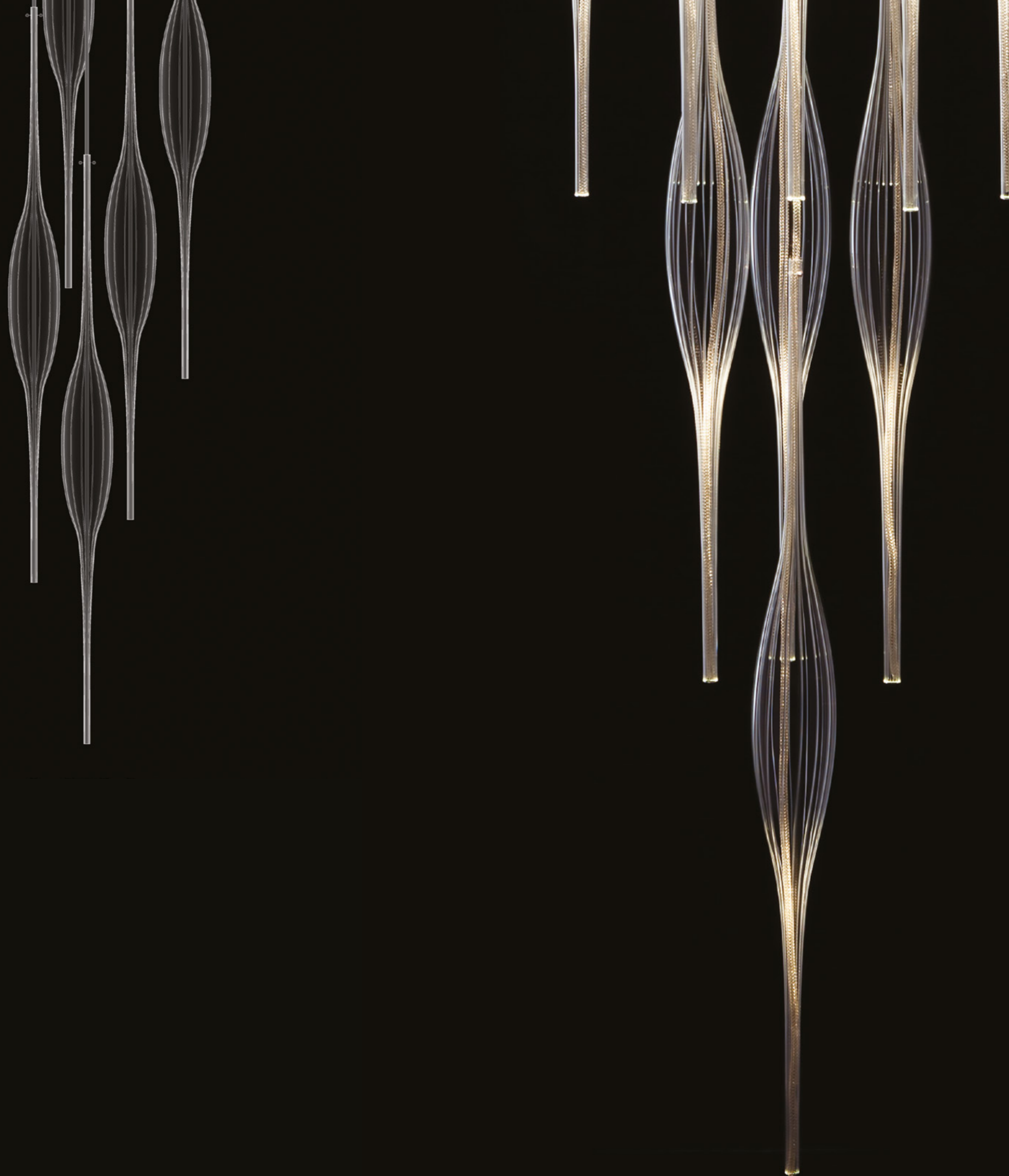

CLEAR OR FROSTED HAND-BLOWN RULED GLASS PENDANT.

One size only: h. 85 - ø 7,5 cm.

Additional inner light can be used with this model (see page 139).



HYDRA

DATURA



CLEAR OR FROSTED HAND-BLOWN RULED GLASS PENDANT.

One size only: h. 48 - ø 18 cm.

Additional inner light can be used with this model (see page 139).



HYDRA

DELTA

FROSTED HAND-BLOWN GLASS PENDANT.

One size only: h. 50 - ø 6,5 cm.

Additional inner light can be used with this model (see page 139).





HYDRA

DIESIS



CLEAR, FROSTED OR METALLIZED HAND-BLOWN RULED GLASS PENDANT.

3 shapes available: ① h. 31 - ø 18 cm. ② h. 26 - ø 18 cm. ③ h. 26 - ø 18 cm.
Additional inner light can be used with this model (see page 139).



Example of Diesis
with inner light.
See page 139.

HYDRA

GAMMA

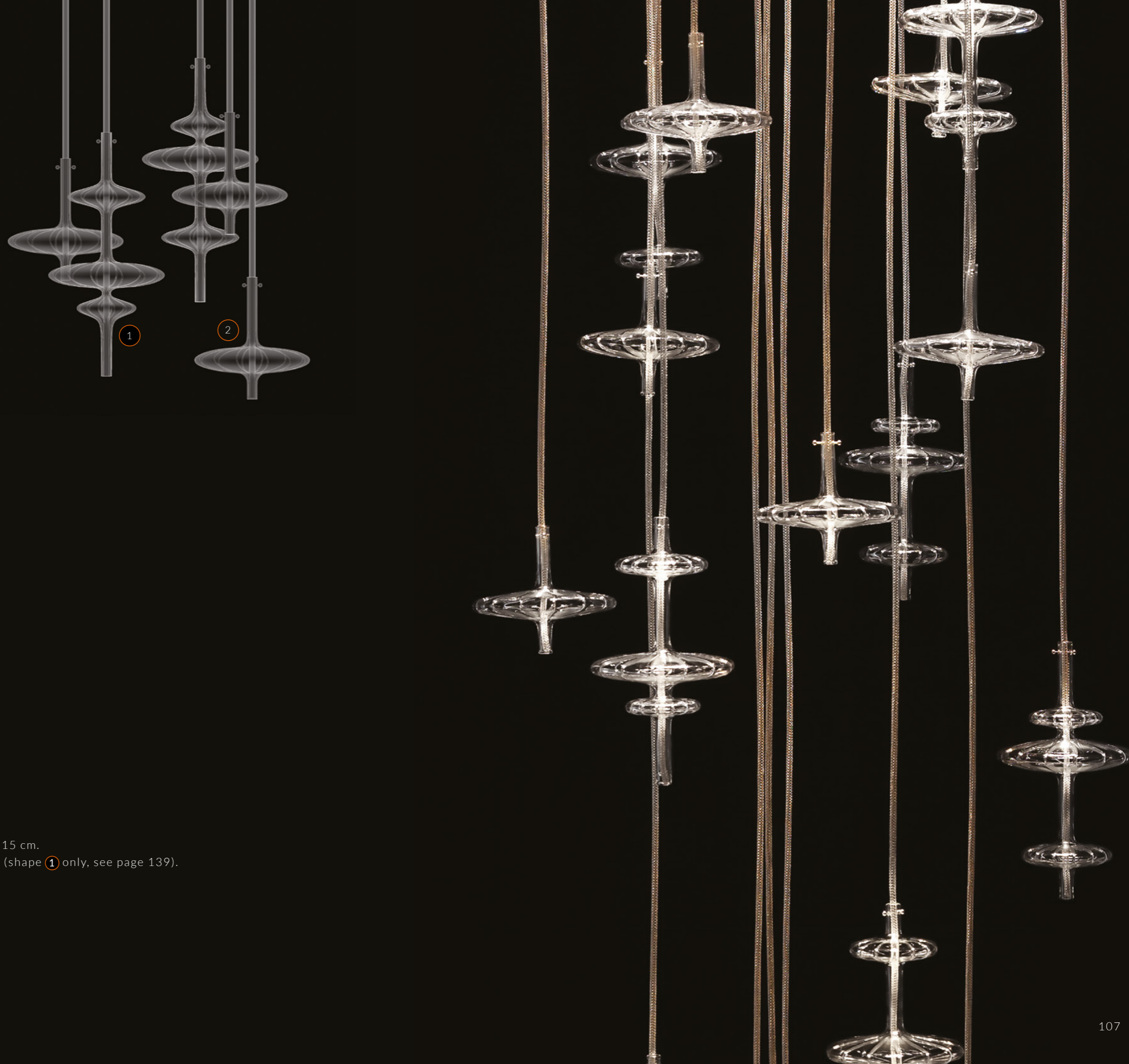

CLEAR HAND-BLOWN RULED GLASS PENDANT.

2 shapes available: ① h. 30 - ø 15 cm. ② h. 17 - ø 15 cm.

Additional inner light can be used with this model (shape ① only, see page 139).



HYDRA

JANUS



CLEAR OR METALLIZED HAND-BLOWN RULED GLASS PENDANT.

2 shapes available. One size only: ø 16 cm.





HYDRA

LAMBDA

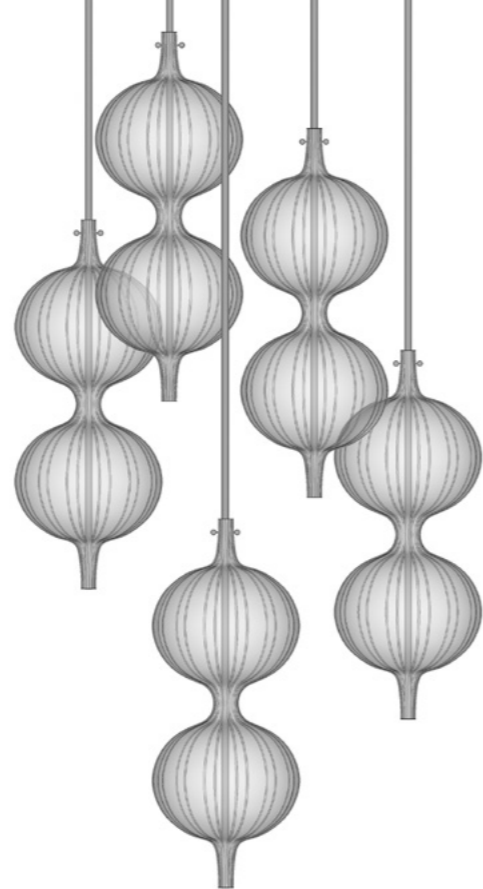

CLEAR OR FROSTED HAND-BLOWN RULED GLASS PENDANT.

One size only: h. 31 - ø 10,5 cm.



HYDRA

LHASA

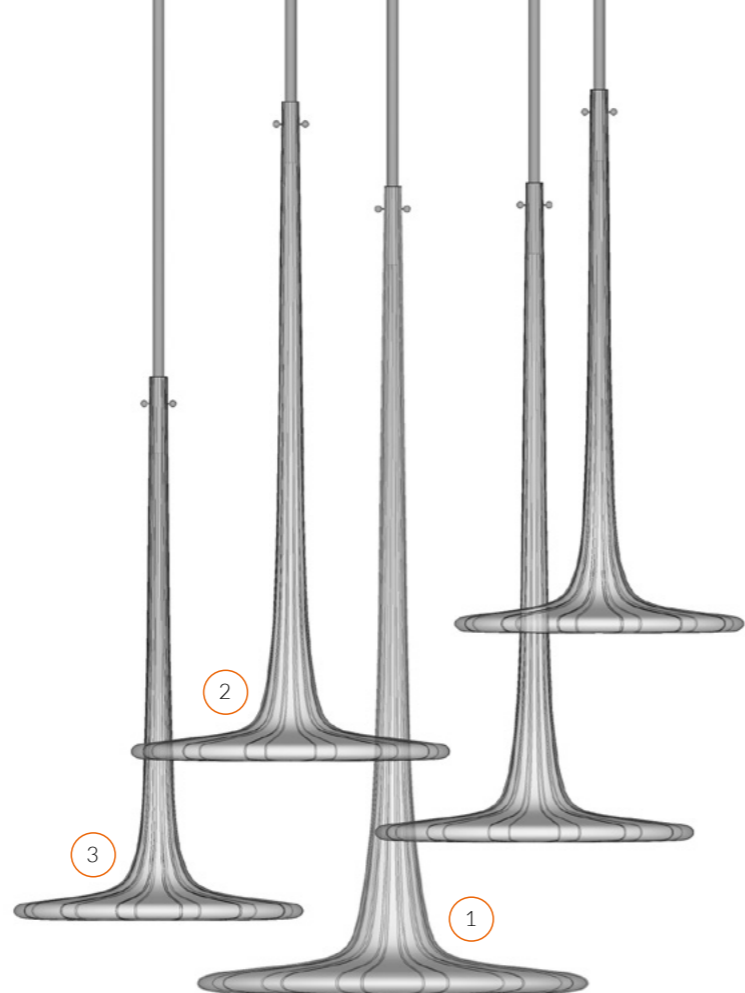

CLEAR OR FROSTED HAND-BLOWN RULED GLASS PENDANT.

3 sizes available: ① h. 56 - ø 27 cm ② h. 45 - ø 22 cm ③ h. 37 - ø 20 cm.



HYDRA

OMEGA

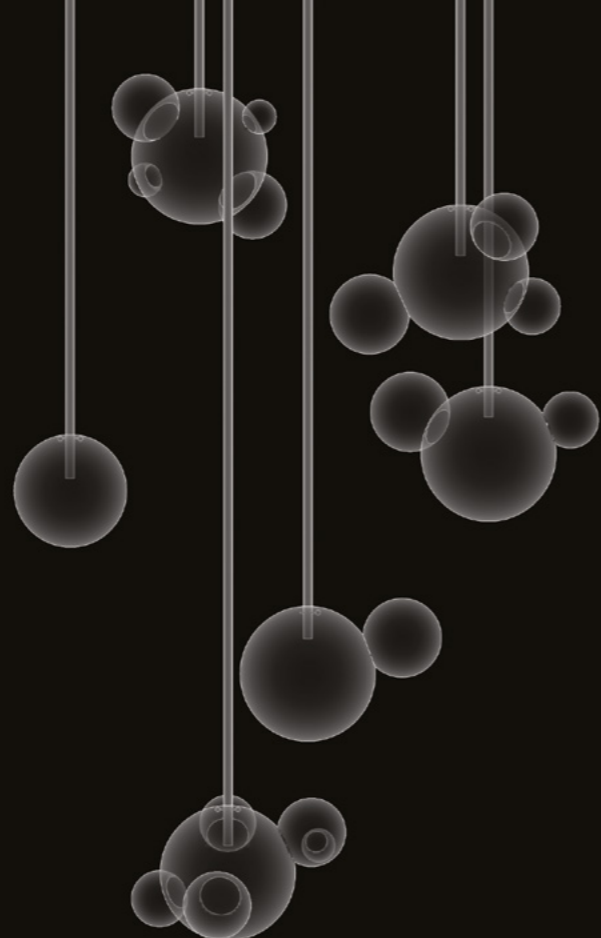

CLEAR HAND-BLOWN GLASS PENDANT.

8 shapes available. From ø 8 up to ø 23 cm.





THE BEAUTY OF
NATURAL IMPERFECTION

HYDRA

ONION

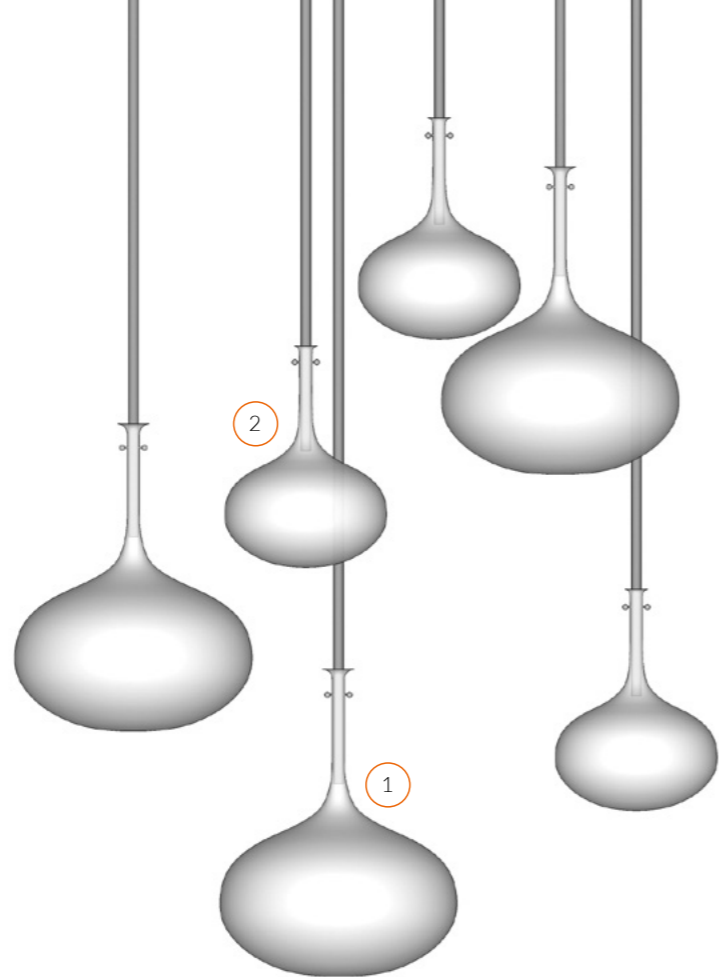

FROSTED HAND-BLOWN GLASS PENDANT.

2 sizes available: ① h. 25 - ø 19 cm. ② h. 18 - ø 13 cm.



HYDRA

ORGANIC

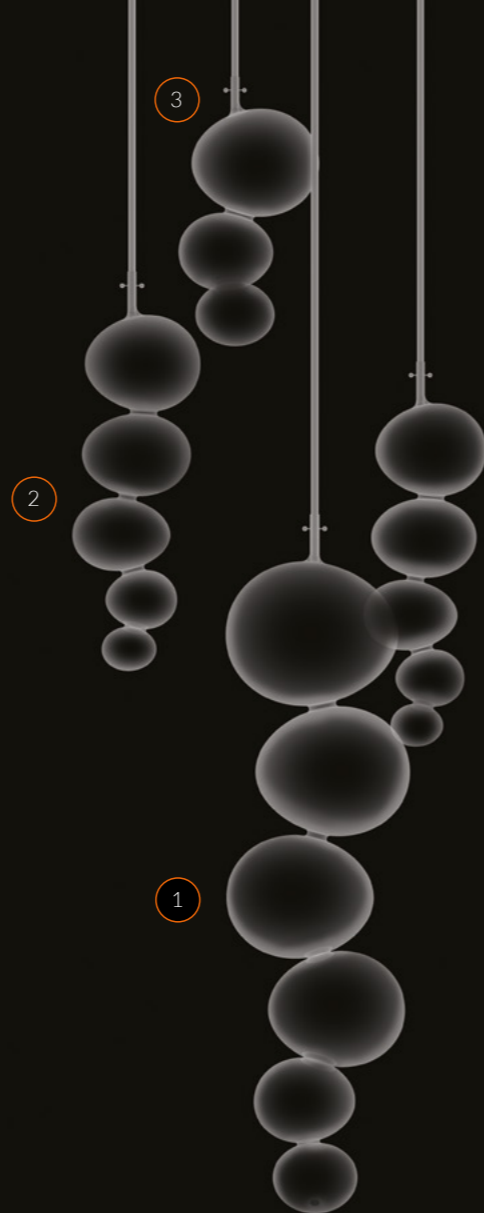

CLEAR OR METALLIZED HAND-BLOWN GLASS PENDANT.

3 shapes available: ① h. 70 - ø 18 cm. ② h. 50 - ø 15 cm. ③ h. 30 - ø 18 cm.



HYDRA

SIGMA

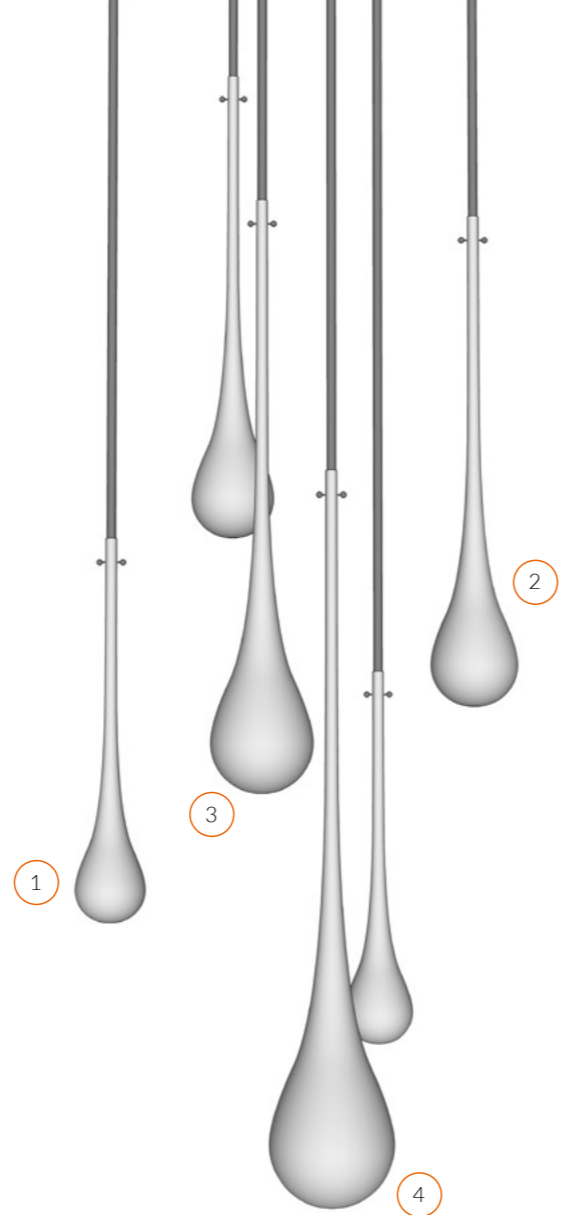

CLEAR OR FROSTED HAND-BLOWN GLASS PENDANT.

4 sizes available: ① h. 35 - ø 7 cm. ② h. 45 - ø 8 cm. ③ h. 55 - ø 9 cm. ④ h. 65 - ø 11 cm.





SIMPLICITY AND ELEGANCE
OVER THE EXPECTATIONS

HYDRA

STIGMA



CLEAR HAND-BLOWN GLASS PENDANT.

One size only: h. 32 - ø 9 cm.

Additional inner light can be used with this model (see page 139).



HYDRA

THETA



CLEAR HAND-BLOWN GLASS PENDANT.

One size only: h. 47 - ø 5,5 cm.

Additional inner light can be used with this model (see page 139).



HYDRA

VITAMINE

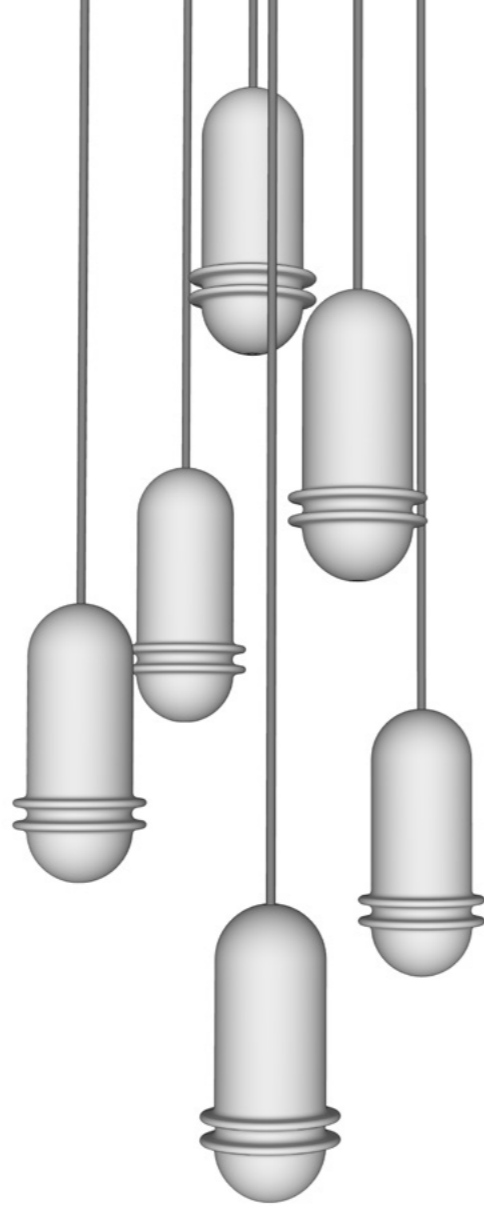

FROSTED HAND-BLOWN GLASS PENDANT.

One size only: h. 26,5 - ø 12,5 cm.

Additional inner light can be used with this model (see page 139).



HYDRA

VITAMINE METAL

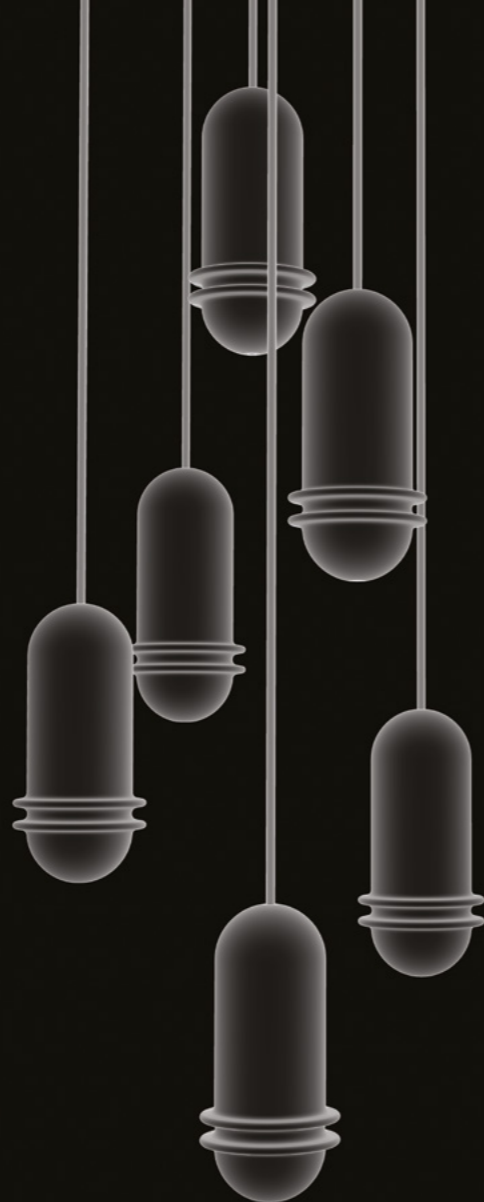

METALLIZED HAND-BLOWN GLASS PENDANT.

One size only: h. 26,5 - ø 12,5 cm.

Additional inner light can be used with this model (see page 139).



LED CEILING LIGHTS

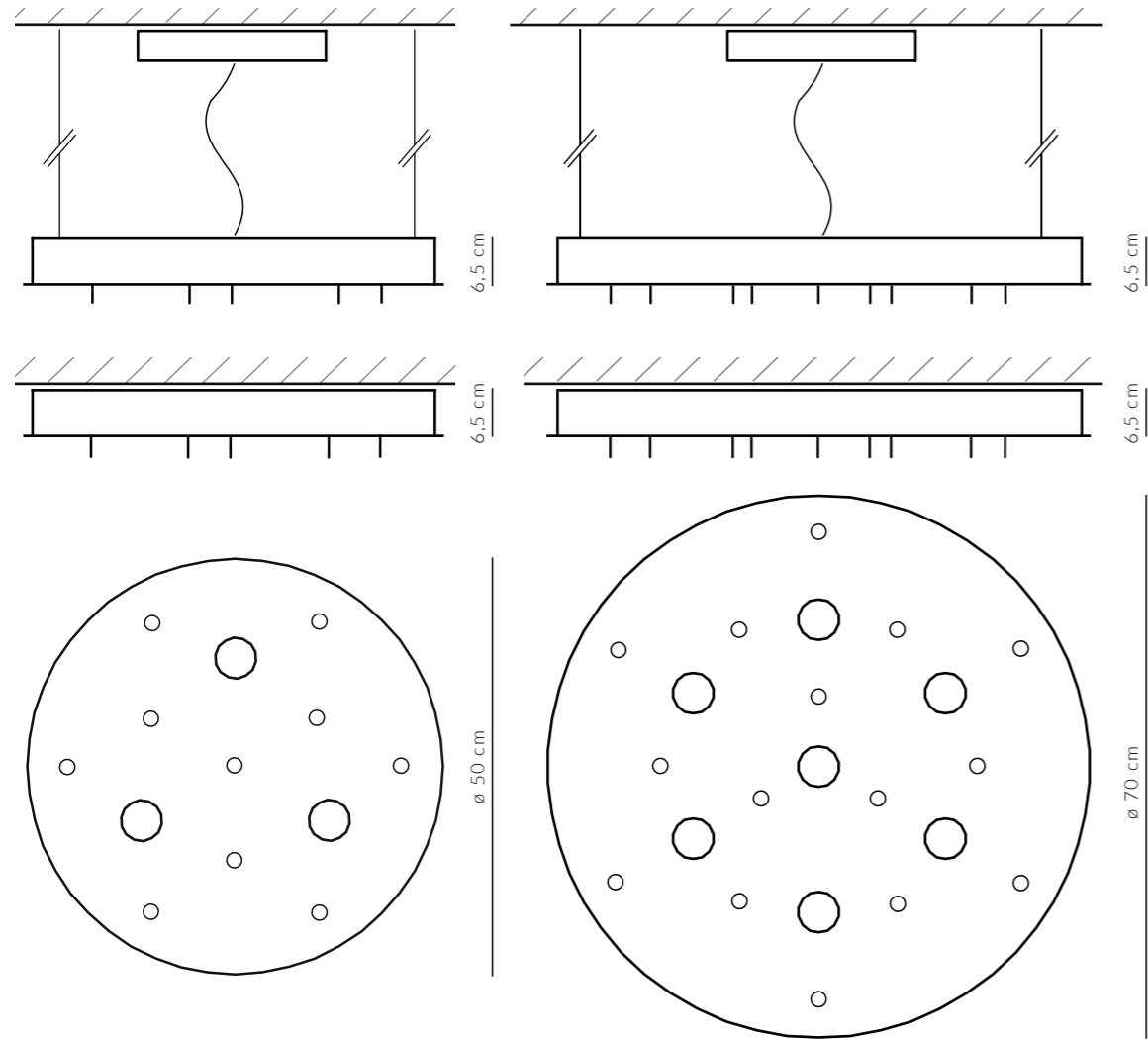

ROUND METAL CEILING.

SMALL_ø 50 cm. Varnished or mirror finishing.
3 x 10W power LED dimmable, 2700k optic 10°.
10 fixing supports for metallic mesh ropes.

LARGE_ø 70 cm. Varnished or mirror finishing.
7 x 10W power LED dimmable, 2700k optic 10°.
15 fixing supports for metallic mesh ropes.

melogranoblu can design and produce customized ceiling lights.





HYDRA SYSTEM

INNER LIGHTS

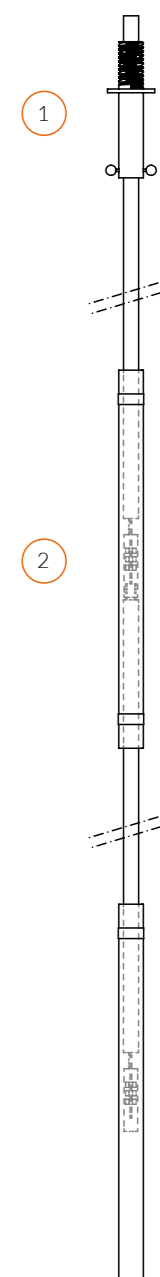

METALLIC MESH ROPE CAN BE ELECTRIFIED,
TO HAVE LIGHT INSIDE GLASSES.

- ① Special fixing support for false ceiling.
- ② Inner light for Hydra System glasses complete with special G4 pin LED bulb 2,5 W melogranoblu patent.

Additional inner light can be used only with following models:

Alpha, Berry metal, Beta, Datura, Delta, Diesis, Gamma ①, Stigma, Theta, Vitamine frosted, Vitamine metal.

HYDRA SYSTEM

TUBE

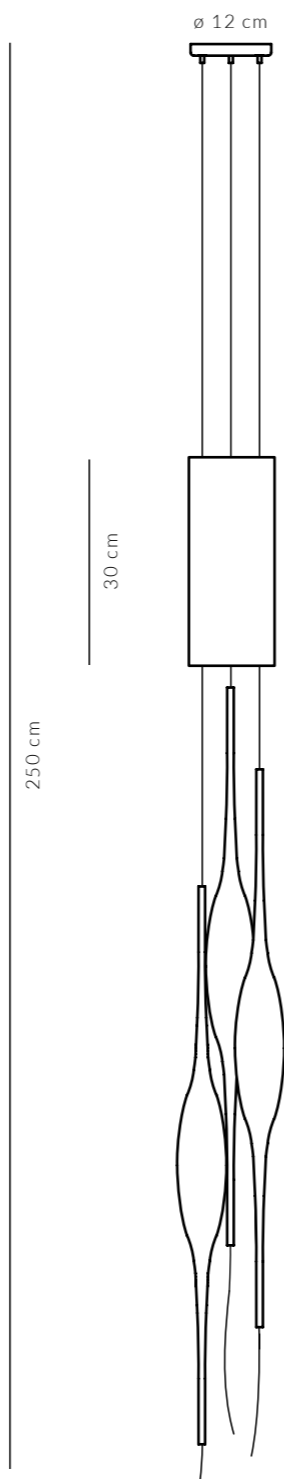

PENDANT LAMP.

Black varnished body, light source 1 x max 50W GU10.
3 colored metallic mesh ropes 2,50 mt. lenght each one.
Glasses: Beta, Theta, Gamma, Lambda, Delta, Sigma, Stigma.





OPERA

COLLECTION OF DECORATIVE PENDANT LAMPS, OBJECTS RICH IN EVOCATIVE ELEMENTS AND LOADED WITH MEMORIES. ICONIC DESIGNS, CAPABLE OF CREATING "FIN DE SIÈCLE" HINTS AND ATMOSPHERES. UNUSUAL YET FAMILIAR FORMS, REASSURING YET CAPABLE OF ASTONISHING. A CONTEMPORARY CLASSIC, ECLECTIC IN STYLE AND AT THE SAME TIME DISCREET ENOUGH TO SUIT ALL SETTINGS.

OPERA

TURANDOT



HANGING-LAMP, RULED HAND-BLOWN GLASS TRANSPARENT OR FROSTED WITH 40 CM. LENGTH TASSEL INCLUDED, ALSO AVAILABLE IN WALL VERSION.

Cable 2,00 mt. length transparent or coated fabric as per color chart.

Glass dimension: Large h. 72 - ø 16 cm. | Small h. 50 - ø 14 cm.

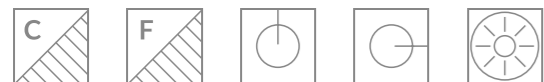

OPERA

CARMEN



HANGING-LAMP, RULED HAND-BLOWN GLASS TRANSPARENT OR FROSTED WITH 40 CM. LENGTH TASSEL INCLUDED, ALSO AVAILABLE IN WALL VERSION.

Cable 2,00 mt. length transparent or coated fabric as per color chart.

Glass dimension: Large h. 56 - ø 16 cm. | Small h. 43 - ø 12 cm.

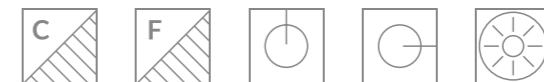

OPERA

DROP



HANGING-LAMP, HAND-BLOWN GLASS FROSTED.

Cable 2,00 mt. lenght transparent or coated fabric as per color chart.

Glass dimension: h. 65 - ø 13 cm.

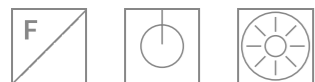

OPERA

POSEIDON EGG



HANGING-LAMP, RULED HAND-BLOWN GLASS TRANSPARENT OR FROSTED WITH 40 CM. LENGHT TASSEL INCLUDED, ALSO AVAILABLE IN WALL VERSION.

Cable 2,00 mt. lenght transparent or coated fabric as per color chart.

Glass dimension: h. 35 - ø 23 cm.

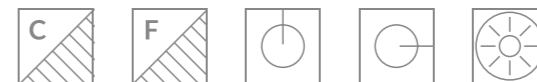

OPERA

POSEIDON GLOBE



HANGING-LAMP, RULED HAND-BLOWN GLASS TRANSPARENT OR FROSTED WITH 40 CM. LENGHT TASSEL INCLUDED, ALSO AVAILABLE IN WALL VERSION.

Cable 2,00 mt. lenght transparent or coated fabric as per color chart.

Glass dimension: Large ø 23 cm. | Small ø 17 cm.

Also available with glass coral branch not included color Black _ Ivory _ Red.

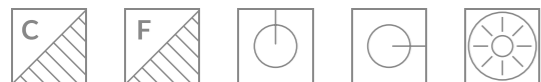

OPERA

ZUCCA



HANGING-LAMP, RULED HAND-BLOWN GLASS TRANSPARENT OR FROSTED.

Cable 2,00 mt. lenght transparent or coated fabric as per color chart.

Glass dimension: h. 60 - ø 20 cm.



OPERA

BAJADERE



HANGING-LAMP, RULED HAND-BLOWN GLASS WITH GLASS PEARLS.

Cable 2,00 mt. lenght transparent or coated fabric as per color chart.

Glass dimension: Small h. 50 - ø 11 cm. | Medium h. 60 ø 13 cm. | Large h. 70 - ø 16 cm.

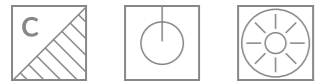

OPERA

CALAF



HANGING-LAMP, RULED HAND-BLOWN GLASS TRANSPARENT OR FROSTED WITH 40 CM. LENGHT TASSEL INCLUDED, ALSO AVAILABLE IN WALL VERSION.

Cable 2,00 mt. lenght transparent or coated fabric as per color chart.

Glass dimension: Large h. 67 - ø 18 cm. | Small h. 46 - ø 14 cm.

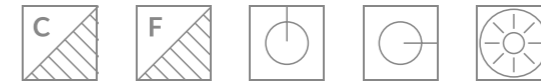

OPERA

NINIVE



HANGING-LAMP, RULED HAND-BLOWN GLASS TRANSPARENT OR FROSTED WITH 40 CM. LENGHT TASSEL INCLUDED, ALSO AVAILABLE IN WALL VERSION.

Cable 2,00 mt. lenght transparent or coated fabric as per color chart.

Glass dimension: Large h. 72 - ø 13 cm. | Small h. 43 - ø 11 cm.

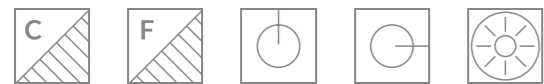

OPERA

TIMUR



HANGING-LAMP, RULED HAND-BLOWN GLASS TRANSPARENT OR FROSTED WITH 40 CM. LENGHT TASSEL INCLUDED, ALSO AVAILABLE IN WALL VERSION.

Cable 2,00 mt. lenght transparent or coated fabric as per color chart.

Glass dimension: Large_h. 53 - ø 18 cm. | Small_h. 41 - ø 15 cm.

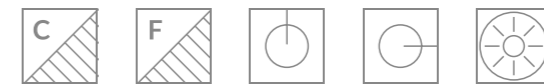

OPERA

LIU "A"



HANGING-LAMP, HAND-BLOWN GLASS TRANSPARENT OR FROSTED WITH 40 CM. LENGHT TASSEL INCLUDED, ALSO AVAILABLE IN WALL VERSION.

Cable 2,00 mt. lenght transparent or coated fabric as per color chart.

Glass dimension: h. 60 - ø 18 cm.

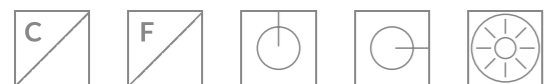

OPERA

LIU "B"



HANGING-LAMP, HAND-BLOWN GLASS TRANSPARENT OR FROSTED WITH 40 CM. LENGHT TASSEL INCLUDED, ALSO AVAILABLE IN WALL VERSION.

Cable 2,00 mt. lenght transparent or coated fabric as per color chart.

Glass dimension: h. 60 - ø 28 cm.

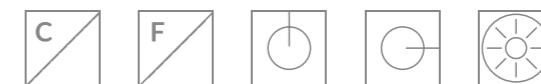

OPERA

LIU "C"



HANGING-LAMP, HAND-BLOWN GLASS TRANSPARENT OR FROSTED WITH 40 CM. LENGTH TASSEL INCLUDED, ALSO AVAILABLE IN WALL VERSION.
Cable 2,00 mt. length transparent or coated fabric as per color chart.
Glass dimension: h. 60 - ø 18 cm.

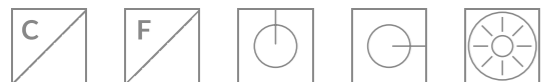

OPERA

MOON



HANGING-LAMP, HAND-BLOWN GLASS FROSTED ALSO AVAILABLE IN WALL VERSION.
Cable 2,00 mt. length transparent or coated fabric as per color chart.
Glass dimension: h. 30 - ø 5 cm.



OPERA

TOP CHANDELIERS



ROUND FIBER GLASS CEILING.

Finishing available: hand made Gold leaf or Silver leaf, varnished in RAL colors.
Dimension: \varnothing 60, 80, 120 and 150 cm x h. 6, 12, 20 and 23 cm.

OPERA

ACCESSORIES

ROUND WOODEN CEILING LIGHTS MOUNT

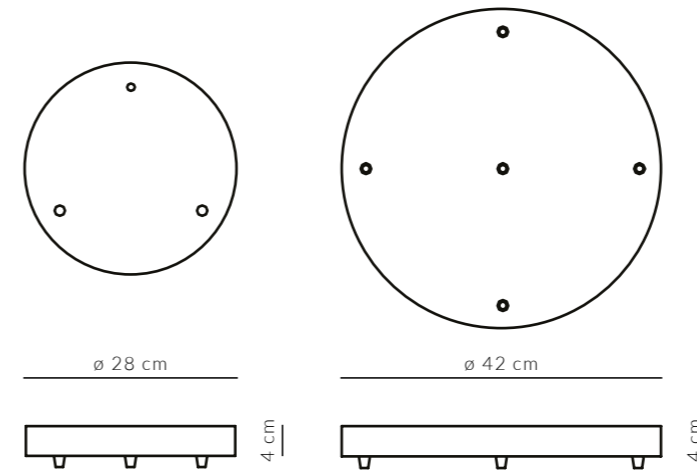
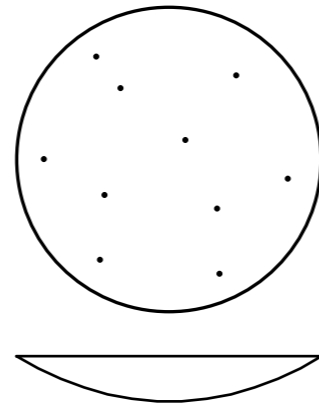

RECTANGULAR WOODEN CEILING LIGHTS MOUNT

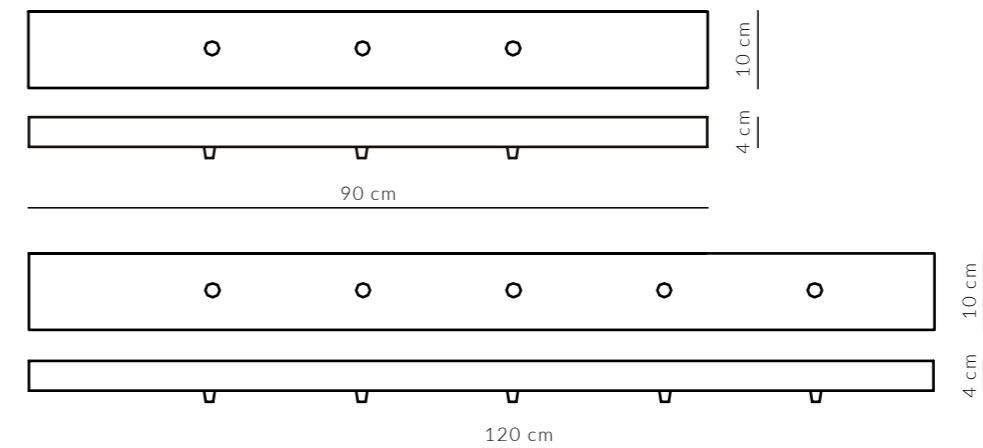

ROUND WOODEN BRACKET

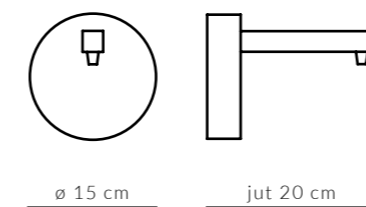

RECTANGULAR WOODEN BRACKET

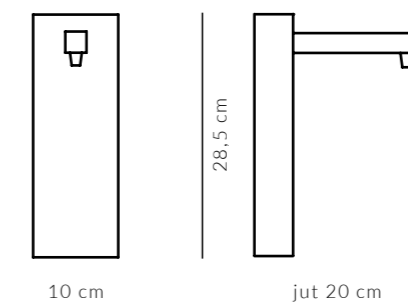

TASSELS AND CABLES

#06 Natural

#600 Hemp

#46 Sage

#19 Brown

#05 Gold

#07 Silver

#09 Dark gray

#28 Avio

#03 Light Blue

#29 Turquoise

#12 China Blue

#14 Navy Blue

#17 Dark Green

#43 Lime Green

#27 Light Green

#25 Pink

#34 Fuxia

#35 Wistaria

#36 Purple

#516 Dark Red

#11 Red

#39 Orange

#04 Yellow

#21 Black

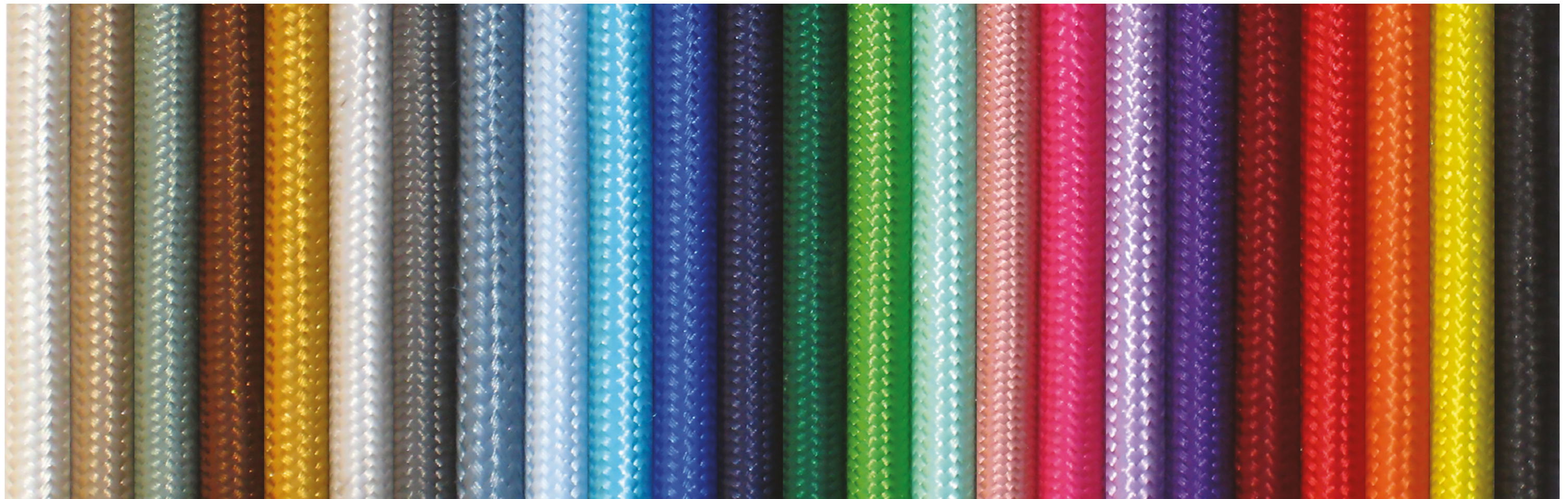

Colors in this catalogue may lightly vary because of printing.

melgranoblu reserve the right to modify products and colors, without notice, in order to make technical improvements.

CREDITS

COPYRIGHT

© 2017 by melogranoblu srl



CATALOGUE DESIGN

BABOL COMMUNICATION
www.babolcommunication.com

melogranoblu

Via Boschetti, 87

24050 Grassobbio

Bergamo _ Italy

Ph +39 035 4522451

Fax +39 035 19961841

sales@melogranoblu.com

www.melogranoblu.com

